

PCMflash module 77

ME9/MED9/EDC7/EDC16/PSG16/TCU Bootloader

Contents/Оглавление

| | |
|--------------------------|----|
| Contents/Оглавление..... | 2 |
| EDC7C1 | 4 |
| EDC7C3 | 5 |
| EDC7C4-6 (EDC16C31)..... | 6 |
| EDC7C32 | 7 |
| EDC7UC31..... | 8 |
| EDC16C1 | 9 |
| EDC16C2 | 10 |
| EDC16C3 | 11 |
| EDC16C7 | 12 |
| EDC16C8 | 13 |
| EDC16C9 | 14 |
| EDC16C10 | 15 |
| EDC16C31 | 16 |
| EDC16C32 | 17 |
| EDC16C34 | 18 |
| EDC16C35 | 19 |
| EDC16C36 | 20 |
| EDC16C37 | 21 |
| EDC16C39 | 22 |
| EDC16C41 | 23 |
| EDC16CP31 | 24 |
| EDC16CP33 | 25 |
| EDC16CP34 | 26 |
| EDC16CP35 | 27 |
| EDC16CP36 | 28 |
| EDC16CP39 | 29 |
| EDC16CP42 | 30 |

| | |
|------------------------------|----|
| EDC16U1/U31/U34/CP34..... | 31 |
| ME(D)9.6/ME(D)9.6.1 | 32 |
| ME9.0..... | 33 |
| MED9.1/MED9.1.1 | 34 |
| MED9.5.10 | 35 |
| PSG16 | 36 |
| 6HPxx Bosch TCU | 37 |
| RE5R05A 0260550002 TCU | 38 |
| RE5R05A 0260550023 TCU | 40 |
| TC14 TCU..... | 41 |

PCMflash

Engine Control Unit

EDC7C1

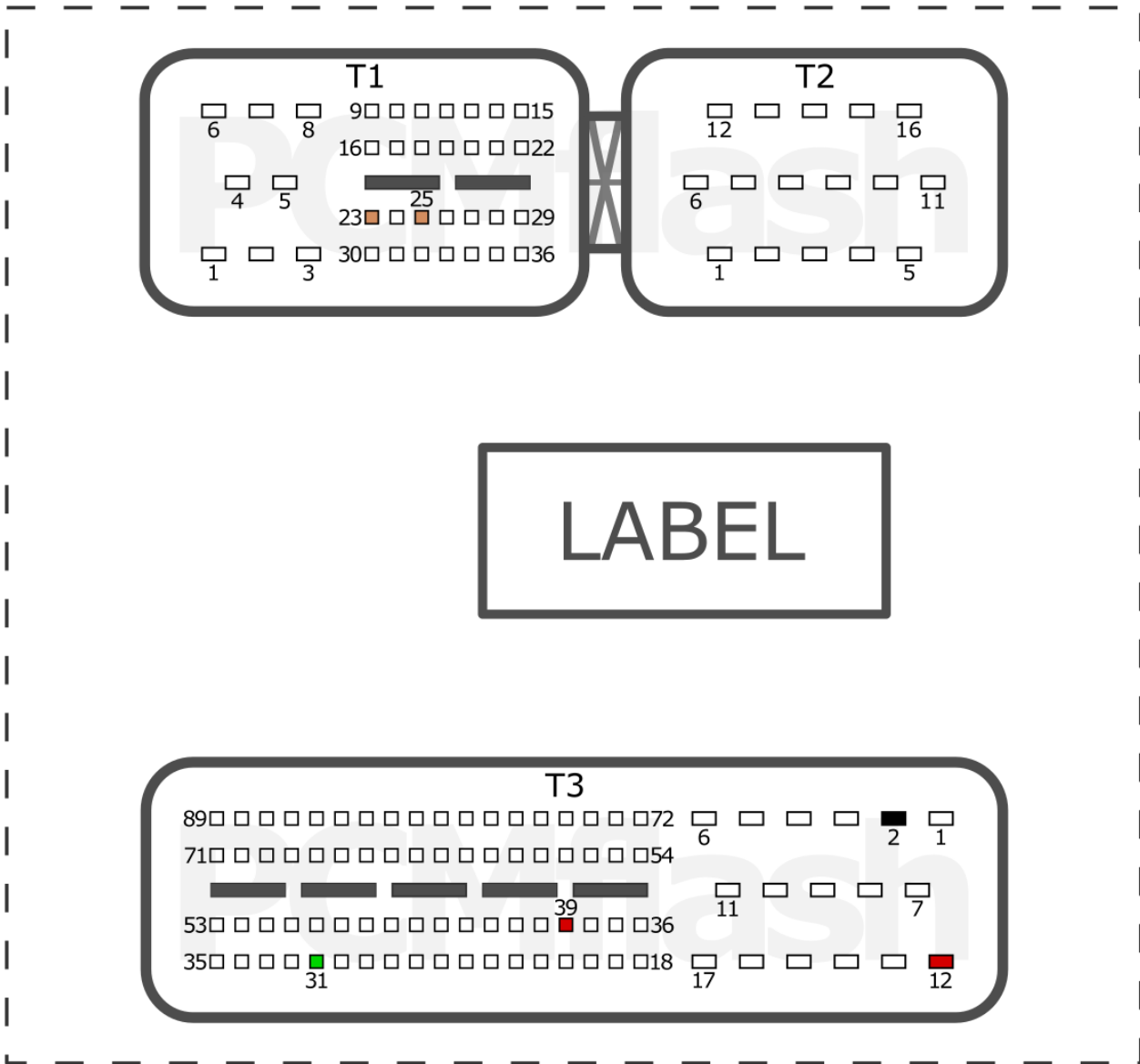

LABEL

| | | | |
|-------------|------------|---------------|------------|
| +12V | T3: 39, 12 | GPT* | T1: 23, 25 |
| GND | T3: 2 | K-LINE | T3: 31 |

*Install 10-50 uF capacitors on each GPT line

BUS/TRUCK

pcmflash.ru

v.1

2021-11-09

PCMflash

Engine Control Unit

EDC7C3

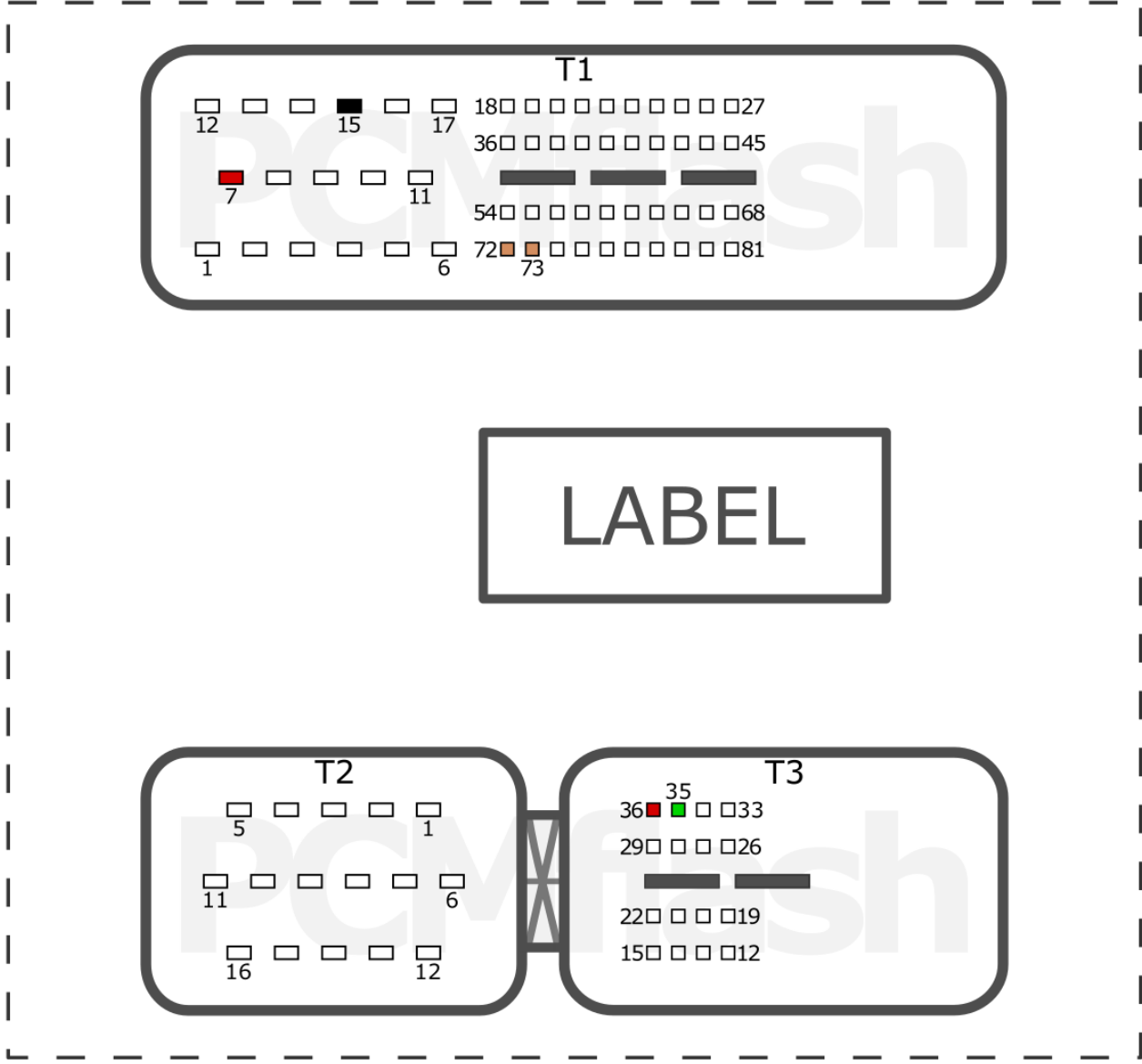

| | | | |
|---|---------------|---------------|------------|
| +12V | T1: 7, T3: 36 | GPT* | T1: 72, 73 |
| GND | T1: 15 | K-LINE | T3: 35 |
| *Install 10-50 uF capacitors on each GPT line | | | |

MAN

pcmflash.ru

v.1

2021-08-05

PCMflash

Engine Control Unit

EDC7C4-6 (EDC16C31)

T96

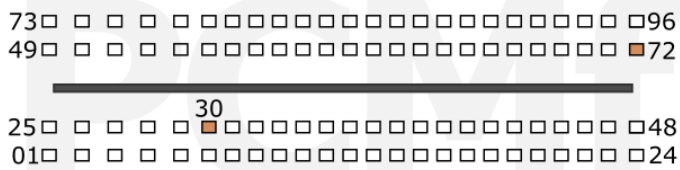

T58

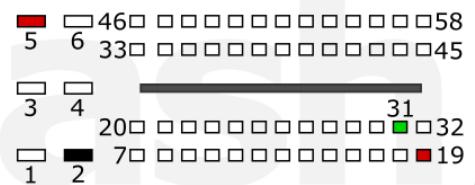

| | | | |
|-------------|------------|---------------|-------------|
| +12V | T58: 5, 19 | GPT | T96: 30, 72 |
| GND | T58: 2 | K-LINE | T58: 31 |

MITSUBISHI

pcmflash.ru

v.1

2021-07-29

PCMflash

Engine Control Unit

EDC7C32

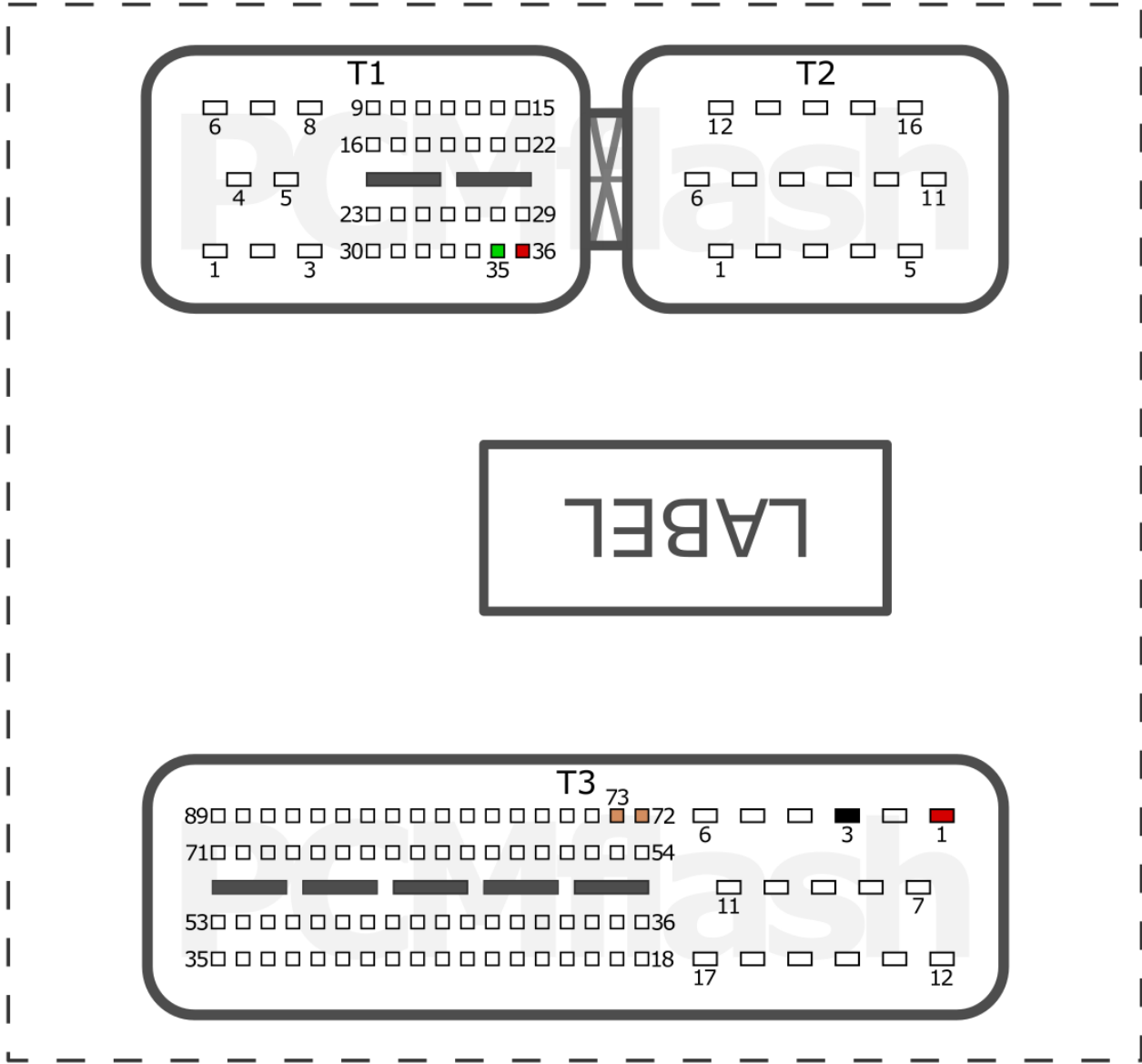

| | | | |
|-------------|---------------|---------------|------------|
| +12V | T1: 36, T3: 1 | GPT* | T3: 72, 73 |
| GND | T3: 3 | K-LINE | T1: 35 |

*Install 10-50 uF capacitors on each GPT line

MAN

pcmflash.ru

v.1

2021-05-08

PCMflash

Engine Control Unit

EDC7UC31

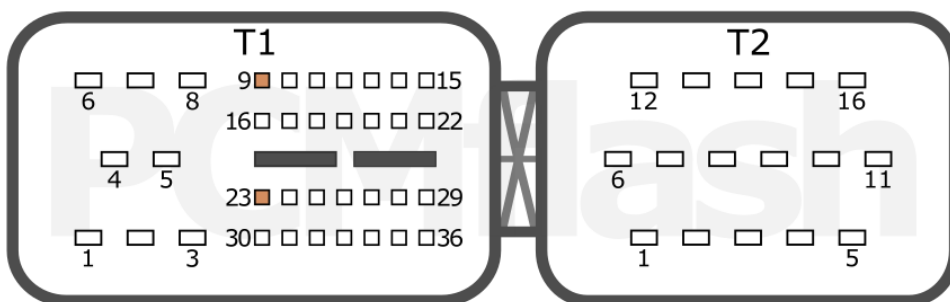

LABEL

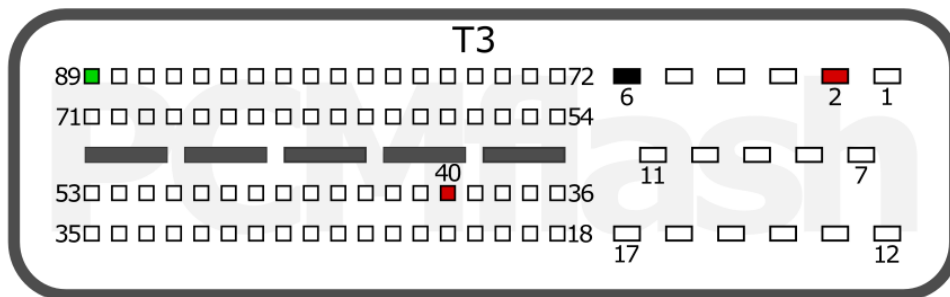

| | | | |
|-------------|-----------|---------------|-----------|
| +12V | T3: 40, 2 | GPT* | T1: 9, 23 |
| GND | T3: 6 | K-LINE | T3: 89 |

*Install 10-50 uF capacitors on each GPT line

BUS/TRUCK

pcmflash.ru

v.1

2021-08-04

PCMflash

Engine Control Unit

EDC16C1

T96

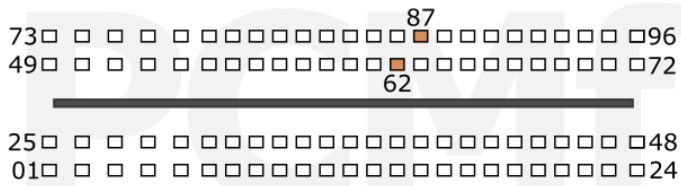

T58



| | | | |
|-------------|-----------|---------------|-------------|
| +12V | T58: 1, 7 | GPT | T96: 62, 87 |
| GND | T58: 2 | K-LINE | T58: 8 |

BMW

pcmflash.ru

v.1

2021-08-08

PCMflash

Engine Control Unit

EDC16C2

Connection version 1

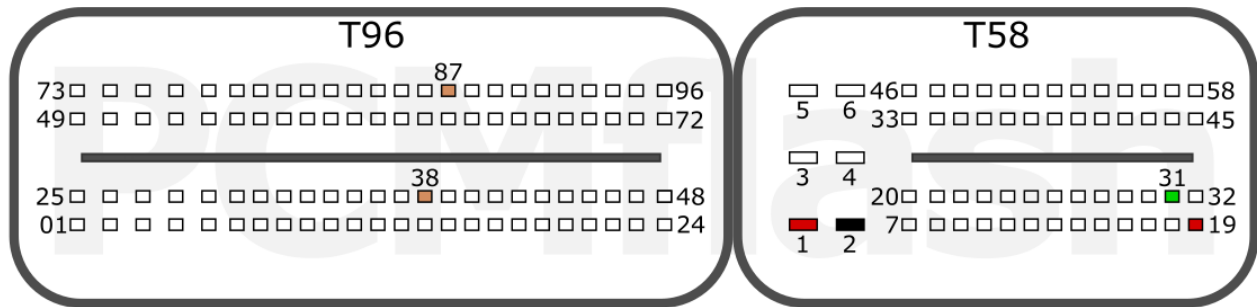

| | | | |
|-------------|------------|---------------|-------------|
| +12V | T58: 1, 19 | GPT | T96: 87, 38 |
| GND | T58: 2 | K-LINE | T58: 31 |

Connection version 2

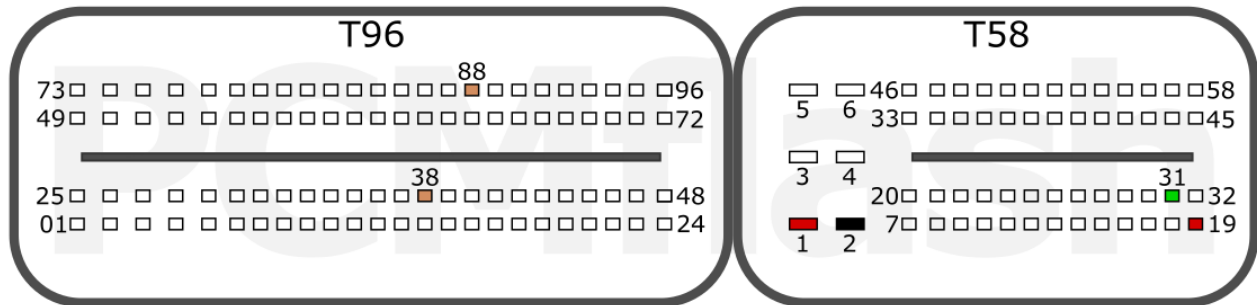

| | | | |
|-------------|------------|---------------|-------------|
| +12V | T58: 1, 19 | GPT | T96: 88, 38 |
| GND | T58: 2 | K-LINE | T58: 31 |

CHRYCLER

MB

pcmflash.ru

v.1

2021-07-28

PCMflash

Engine Control Unit

EDC16C3

NISSAN, RENAULT, SUZUKI

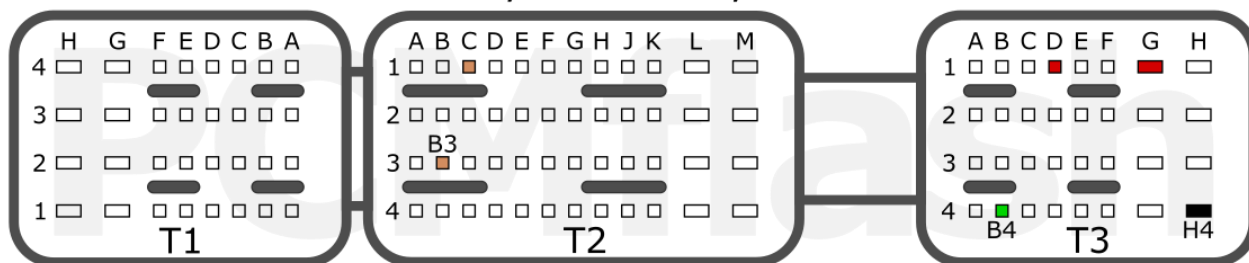

| | | | |
|-------------|------------|---------------|------------|
| +12V | T3: D1, G1 | GPT | T2: C1, B3 |
| GND | T3: H4 | K-LINE | T3: B4 |

NISSAN, RENAULT

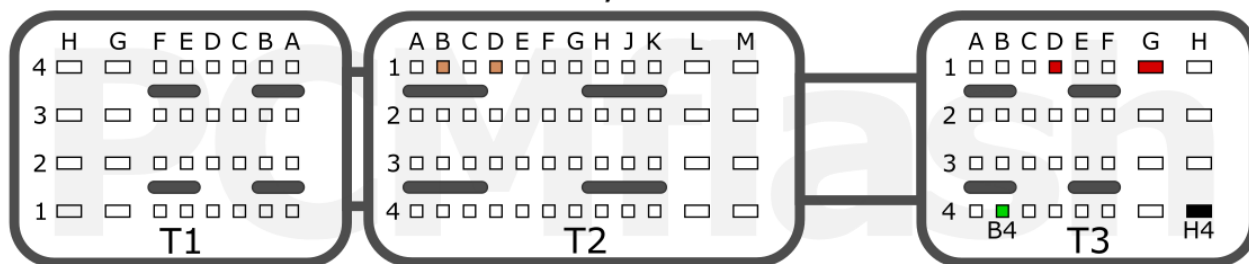

| | | | |
|-------------|------------|---------------|------------|
| +12V | T3: D1, G1 | GPT | T2: B1, D1 |
| GND | T3: H4 | K-LINE | T3: B4 |

PEUGEOT, MAZDA

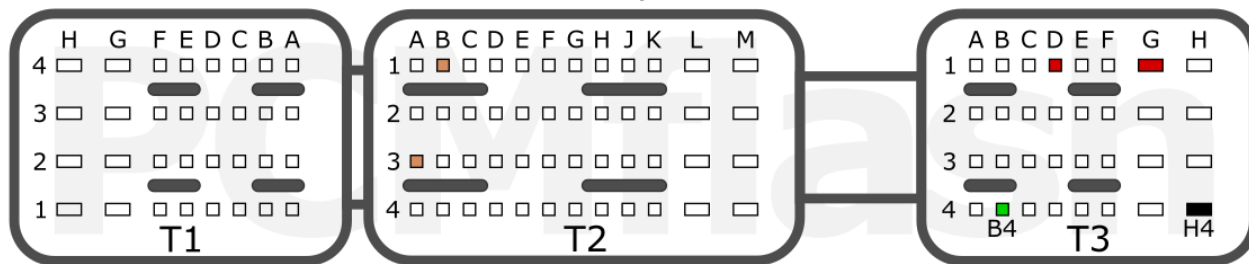

| | | | |
|-------------|------------|---------------|------------|
| +12V | T3: D1, G1 | GPT | T2: B1, A3 |
| GND | T3: H4 | K-LINE | T3: B4 |

MAZDA

NISSAN

PEUGEOT

RENAULT

SUZUKI

pcmflash.ru

v.1

2021-08-04

PCMflash

Engine Control Unit

EDC16C7



| | | | |
|-------------|----------------|---------------|-------------|
| +12V | T58: 3, 35, 25 | GPT | T96: 84, 60 |
| GND | T58: 4 | K-LINE | T58: 31 |

FORD

HONDA

MAZDA

pcmflash.ru

v.1

2021-07-21

PCMflash

Engine Control Unit

EDC16C8

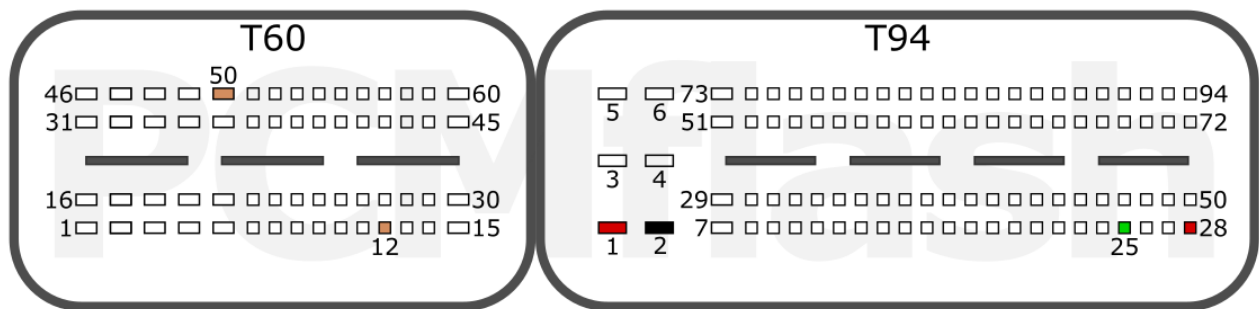

| | | | |
|-------------|------------|---------------|-------------|
| +12V | T94: 1, 28 | GPT | T60: 12, 50 |
| GND | T94: 2 | K-LINE | T94: 25 |

FIAT

pcmflash.ru

v.1

2021-08-05

PCMflash

Engine Control Unit

EDC16C9

Connection version 1

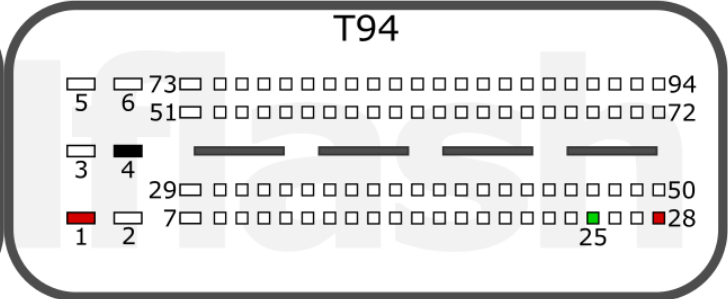
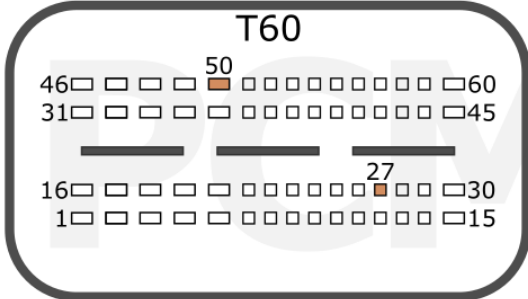

| | | | |
|-------------|------------|---------------|-------------|
| +12V | T94: 1, 28 | GPT | T60: 50, 27 |
| GND | T94: 4 | K-LINE | T94: 25 |

Connection version 2

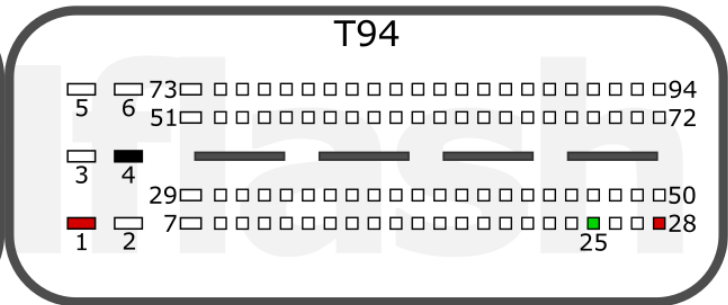
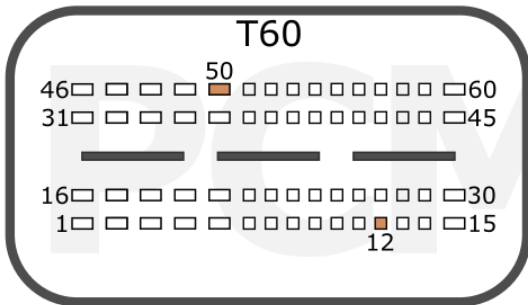

| | | | |
|-------------|------------|---------------|-------------|
| +12V | T94: 1, 28 | GPT | T60: 50, 12 |
| GND | T94: 4 | K-LINE | T94: 25 |

Connection version 3

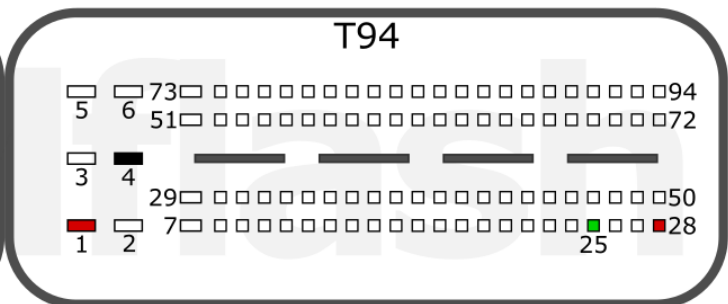
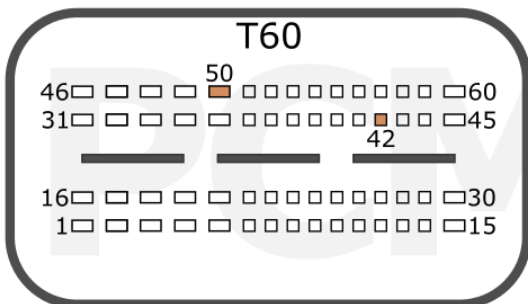

| | | | |
|-------------|------------|---------------|-------------|
| +12V | T94: 1, 28 | GPT | T60: 50, 42 |
| GND | T94: 4 | K-LINE | T94: 25 |

GM

pcmflash.ru

v.2

2021-12-03

PCMflash

Engine Control Unit

EDC16C10

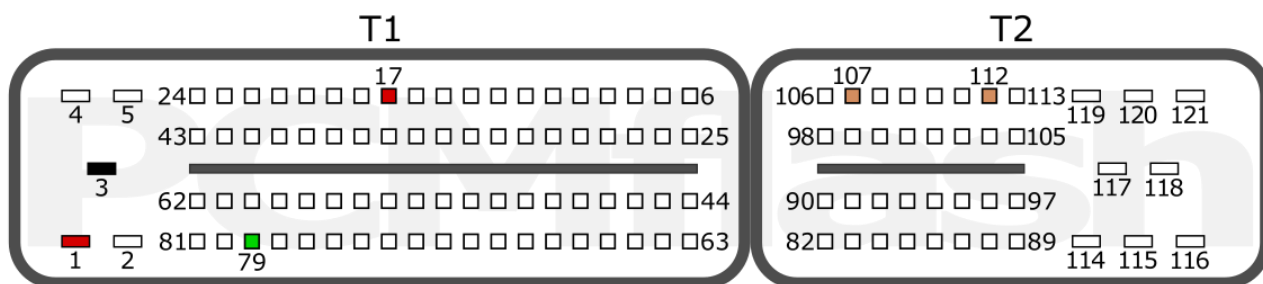

| | | | |
|-------------|-----------|---------------|--------------|
| +12V | T1: 1, 17 | GPT | T2: 107, 112 |
| GND | T1: 3 | K-LINE | T1: 79 |

TOYOTA

pcmflash.ru

v.2

2022-01-21

PCMflash

Engine Control Unit

EDC16C31

Connection version 1



| | | | |
|-------------|------------|---------------|-------------|
| +12V | T58: 5, 41 | GPT | T96: 33, 53 |
| GND | T58: 2 | K-LINE | T58: 43 |

Connection version 2



| | | | |
|-------------|------------|---------------|-------------|
| +12V | T58: 5, 41 | GPT | T96: 66, 77 |
| GND | T58: 2 | K-LINE | T58: 43 |

VOLVO

pcmflash.ru

v.1

2021-11-26

PCMflash

Engine Control Unit

EDC16C32

Connection version 1

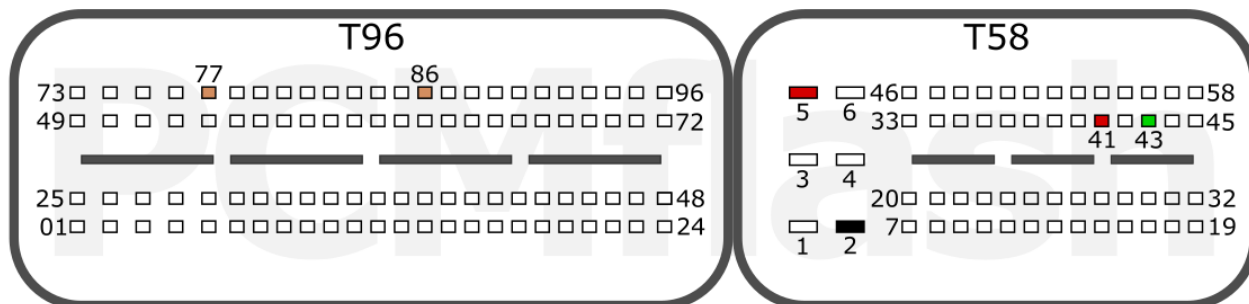

| | | | |
|-------------|------------|---------------|-------------|
| +12V | T58: 5, 41 | GPT | T96: 77, 86 |
| GND | T58: 2 | K-LINE | T58: 43 |

Connection version 2



| | | | |
|-------------|------------|---------------|-------------|
| +12V | T58: 5, 41 | GPT | T96: 77, 33 |
| GND | T58: 2 | K-LINE | T58: 43 |

MB

pcmflash.ru

v.1

2021-07-29

PCMflash

Engine Control Unit

EDC16C34

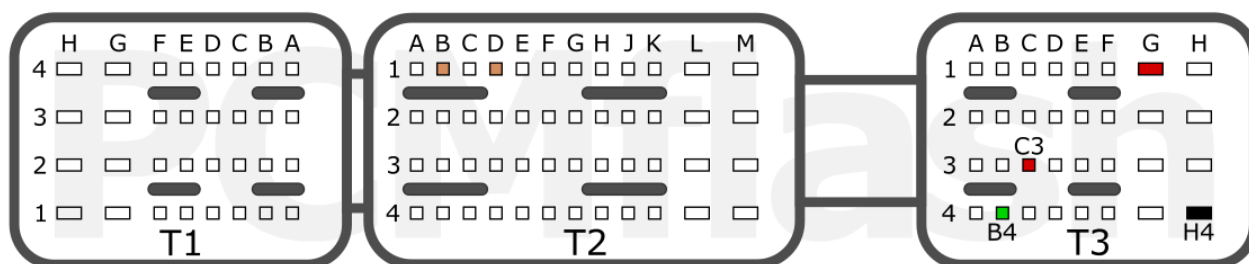

| | | | |
|-------------|------------|---------------|------------|
| +12V | T3: G1, C3 | GPT | T2: B1, D1 |
| GND | T3: H4 | K-LINE | T3: B4 |

FORD

VOLVO

pcmflash.ru

v.1

2021-08-03

PCMflash

Engine Control Unit

EDC16C36

Connection version 1

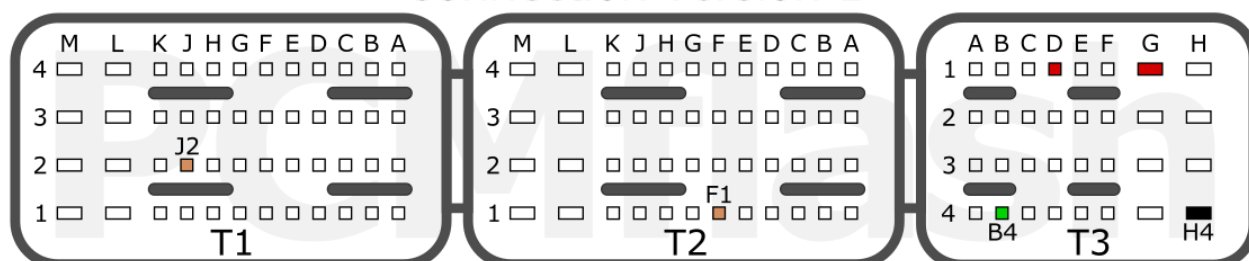

| | | | |
|-------------|------------|---------------|---------------|
| +12V | T3: D1, G1 | GPT | T1: J2, T2:F1 |
| GND | T3: H4 | K-LINE | T3: B4 |

Connection version 2

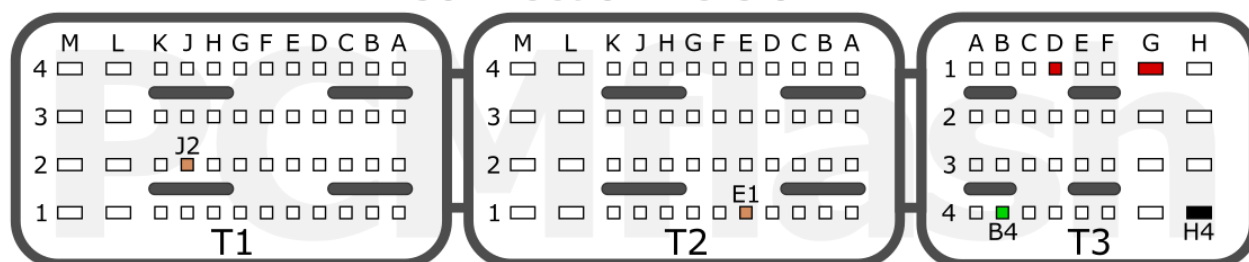

| | | | |
|-------------|------------|---------------|----------------|
| +12V | T3: D1, G1 | GPT | T1: J2, T2:E1* |
| GND | T3: H4 | K-LINE | T3: B4 |

*10uF 50v capacitor required on E1 GPT line

Connection version 3

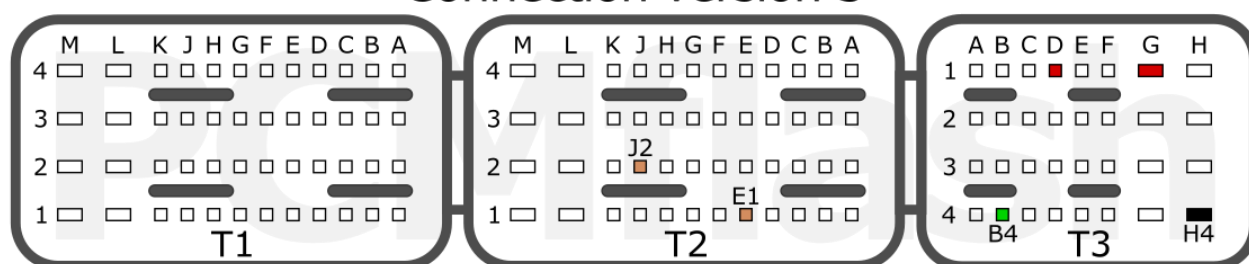

| | | | |
|-------------|------------|---------------|-------------|
| +12V | T3: D1, G1 | GPT | T2: J2, E1* |
| GND | T3: H4 | K-LINE | T3: B4 |

*10uF 50v capacitor required on E1 GPT line

RENAULT

pcmflash.ru

v.2

2022-01-24

PCMflash

Engine Control Unit

EDC16C37



| | | | |
|-------------|------------|---------------|------------|
| +12V | T58: 5, 21 | GPT | T96: 79, 5 |
| GND | T58: 2 | K-LINE | T58: 43 |

GM

pcmflash.ru

v.1

2021-11-03

PCMflash

Engine Control Unit

EDC16C39

CHEVROLET, FIAT, HYUNDAI, IVECO, KIA, UAZ

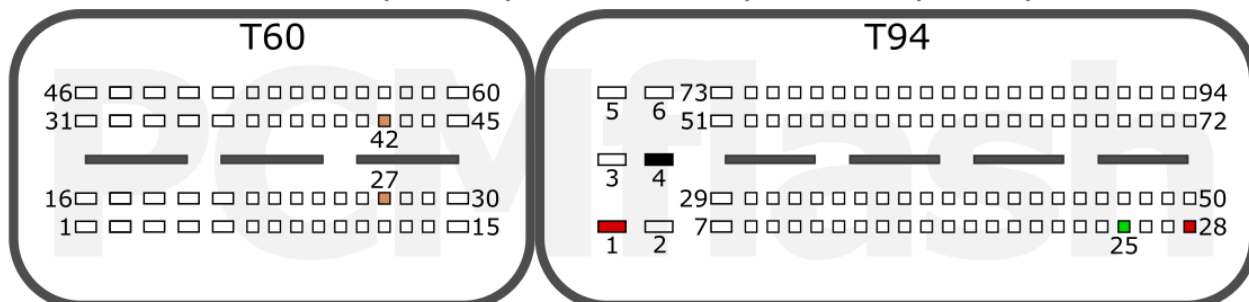

| | | | |
|-------------|------------|------------|-------------|
| +12V | T94: 1, 28 | GPT | T60: 42, 27 |
| | GND | | T94: 4 |

CHEVROLET, HYUNDAI

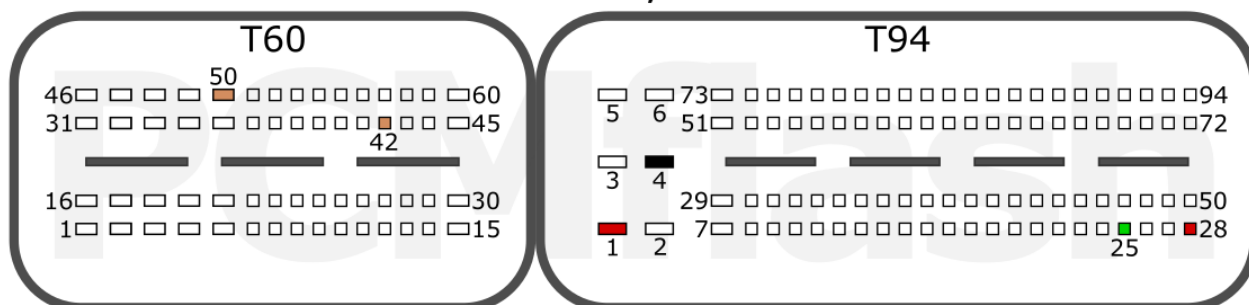

| | | | |
|-------------|------------|------------|-------------|
| +12V | T94: 1, 28 | GPT | T60: 50, 42 |
| | GND | | T94: 4 |

OPEL, SAAB

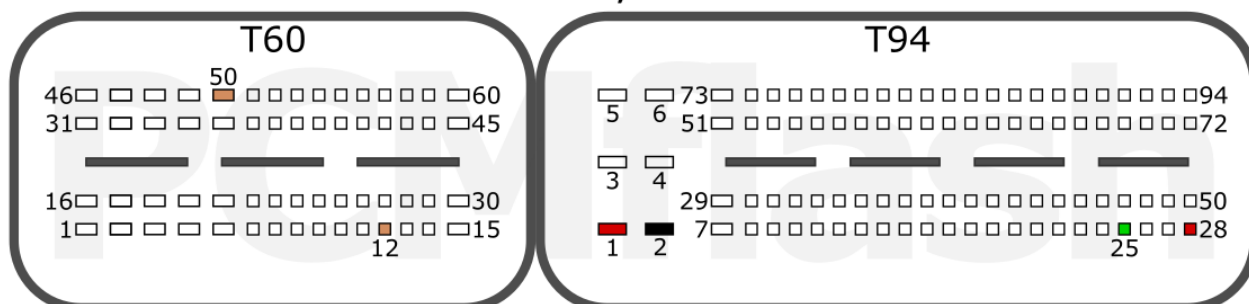

| | | | |
|-------------|------------|------------|-------------|
| +12V | T94: 1, 28 | GPT | T60: 50, 12 |
| | GND | | T94: 2 |

PCMflash

Engine Control Unit

EDC16C41

T96

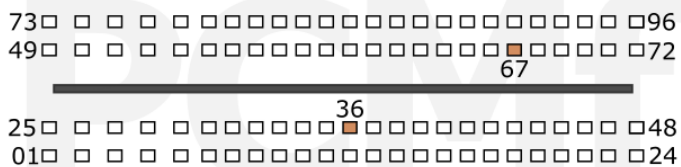

T58



| | | | |
|-------------|------------|---------------|-------------|
| +12V | T58: 5, 19 | GPT | T96: 67, 36 |
| GND | T58: 2 | K-LINE | T58: 16 |

NISSAN

pcmflash.ru

v.1

2021-07-29

PCMflash

Engine Control Unit

EDC16CP33

NISSAN

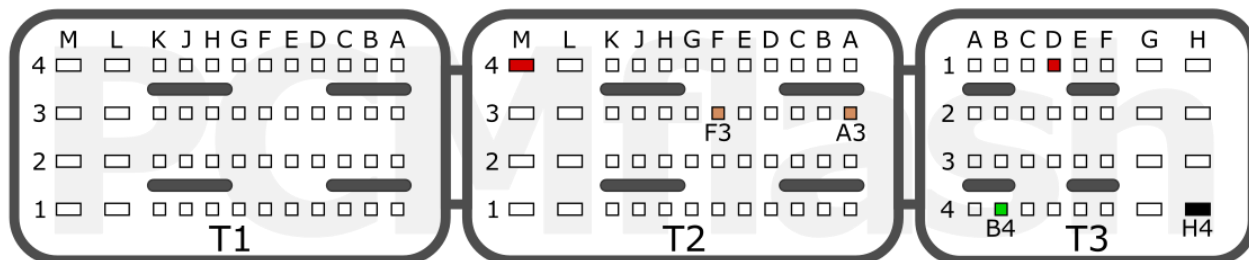

| | | | |
|-------------|----------------|---------------|----------------|
| +12V | T2: M4, T3: D1 | GPT | T2: F3, T2: A3 |
| GND | T3: H4 | K-LINE | T3: B4 |

RENAULT

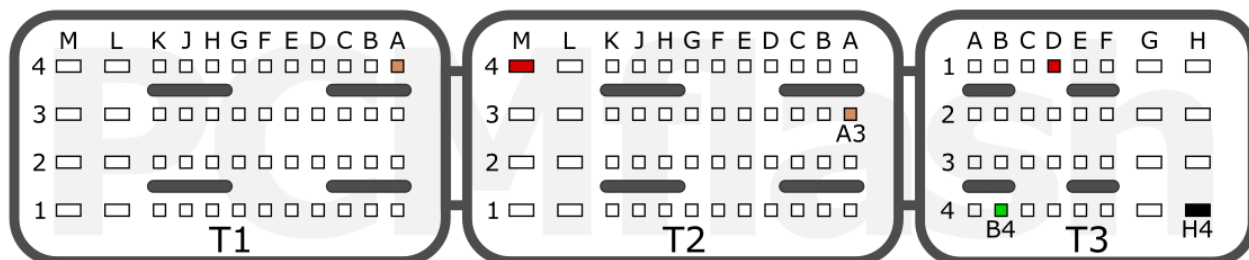

| | | | |
|-------------|----------------|---------------|----------------|
| +12V | T2: M4, T3: D1 | GPT | T1: A4, T2: A3 |
| GND | T3: H4 | K-LINE | T3: B4 |

NISSAN

RENAULT

pcmflash.ru

v.2

2021-12-07

PCMflash

Engine Control Unit

EDC16CP34

Connection version 1

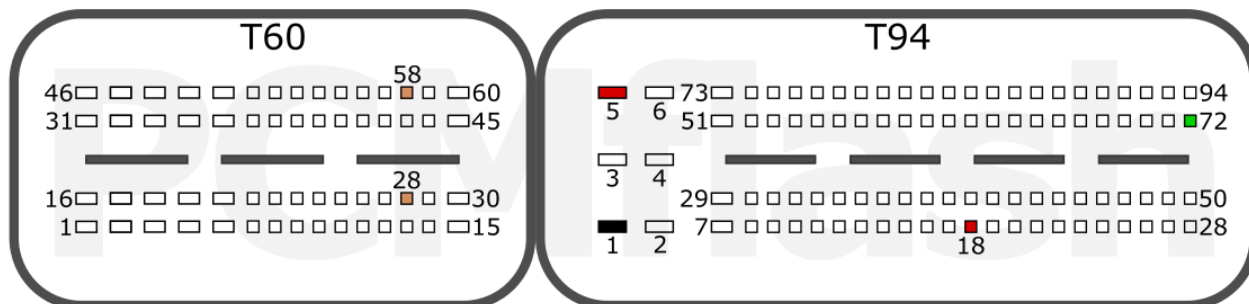

| | | | |
|-------------|------------|---------------|-------------|
| +12V | T94: 5, 18 | GPT | T60: 58, 28 |
| GND | T94: 1 | K-LINE | T94: 72 |

Connection version 2

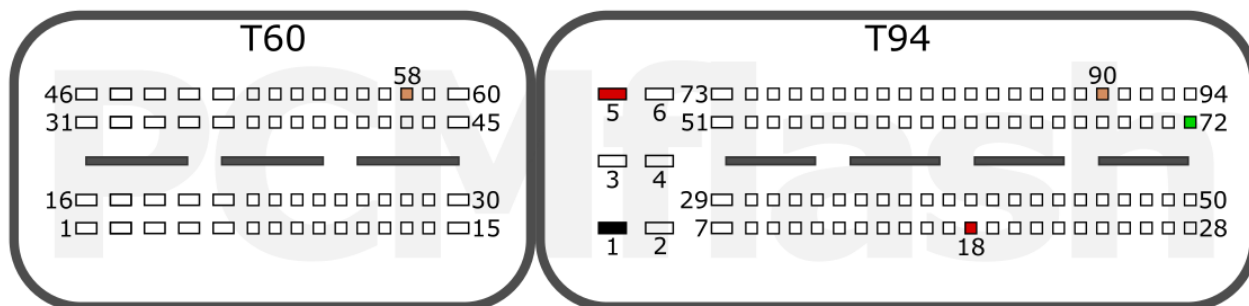

| | | | |
|-------------|------------|---------------|-----------------|
| +12V | T94: 5, 18 | GPT | T60: 58, T94:90 |
| GND | T94: 1 | K-LINE | T94: 72 |

AUDI

pcmflash.ru

v.2

2021-11-03

PCMflash

Engine Control Unit

EDC16CP35

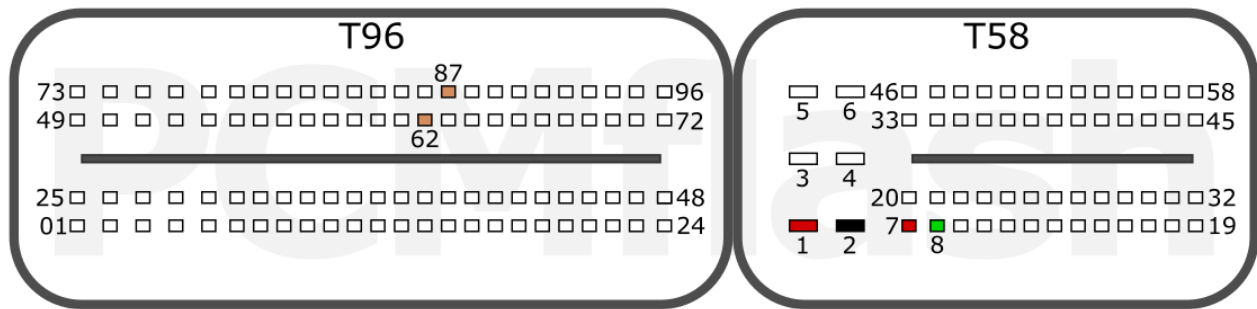

| | | | |
|-------------|-----------|---------------|-------------|
| +12V | T58: 1, 7 | GPT | T96: 87, 62 |
| GND | T58: 2 | K-LINE | T58: 8 |

BMW

pcmflash.ru

v.1

2021-07-27

PCMflash

Engine Control Unit

EDC16CP36



| | | | |
|-------------|----------------|---------------|-------------|
| +12V | T58: 5, 15, 16 | GPT | T96: 33, 77 |
| GND | T58: 2 | K-LINE | T58: 29 |

MB

pcmflash.ru

v.1

2021-08-08

PCMflash

Engine Control Unit

EDC16CP39

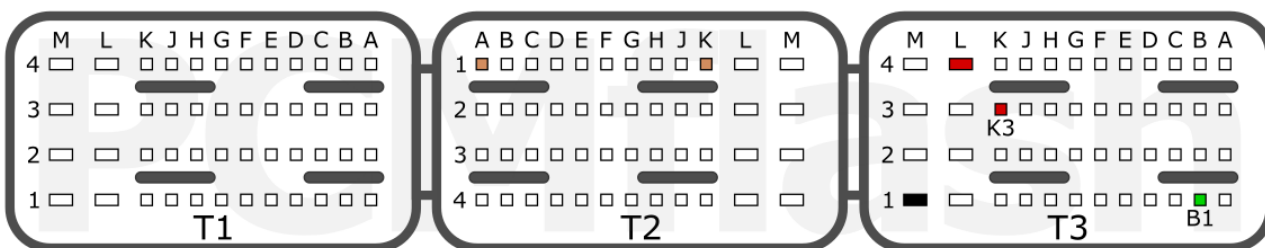

| | | | |
|-------------|------------|---------------|------------|
| +12V | T3: L4, K3 | GPT | T2: A1, K1 |
| GND | T3: M1 | K-LINE | T3: B1 |

FORD

JLR

pcmflash.ru

v.1

2021-08-06

PCMflash

Engine Control Unit

EDC16CP42

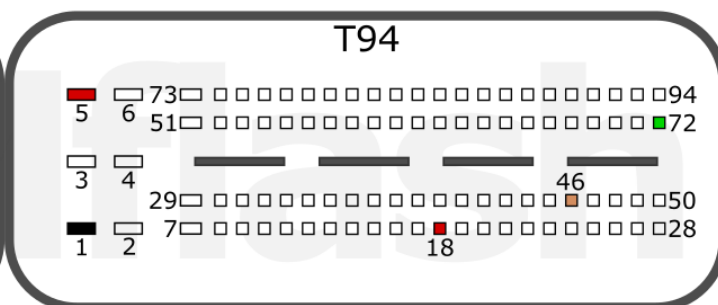
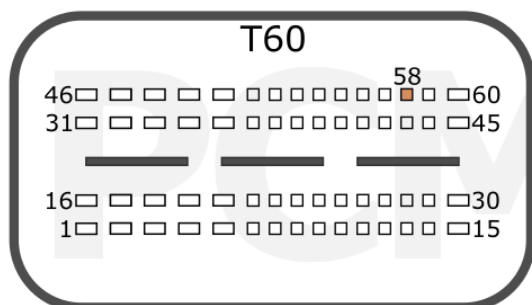

| | | | |
|-------------|------------|---------------|------------------|
| +12V | T94: 5, 18 | GPT | T60: 58; T94: 46 |
| GND | T94: 1 | K-LINE | T94: 72 |

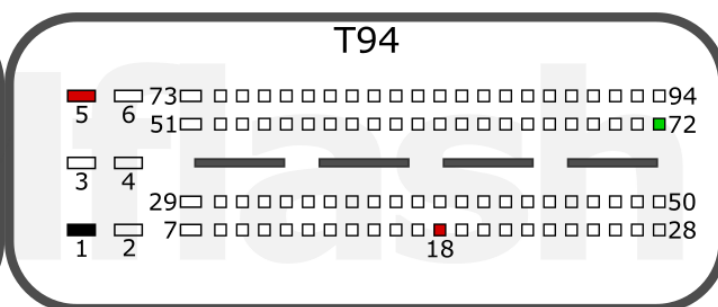
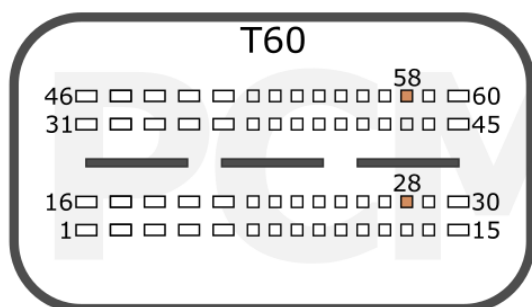

| | | | |
|-------------|------------|---------------|-------------|
| +12V | T94: 5, 18 | GPT | T60: 58, 28 |
| GND | T94: 1 | K-LINE | T94: 72 |

NISSAN

pcmflash.ru

v.1

2021-08-23

PCMflash

Engine Control Unit

EDC16U1/U31/U34/CP34

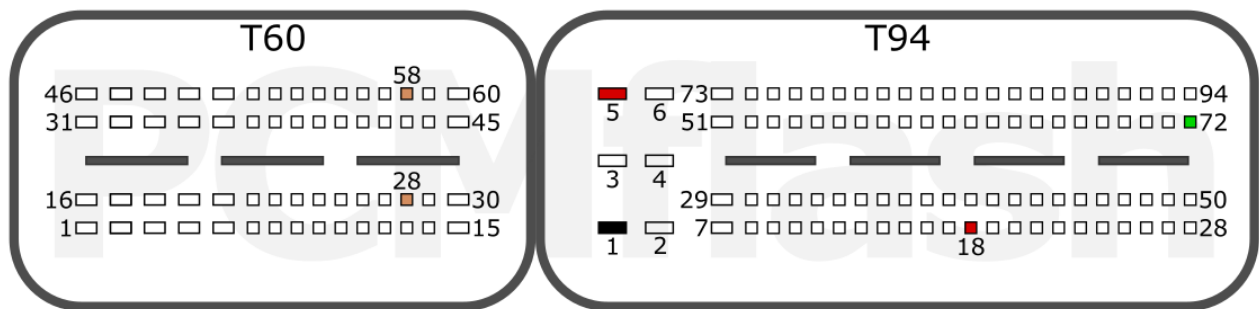

| | | | |
|-------------|------------|---------------|-------------|
| +12V | T94: 5, 18 | GPT | T60: 58, 28 |
| GND | T94: 1 | K-LINE | T94: 72 |

VAG

pcmflash.ru

v.1

2021-07-30

PCMflash

Engine Control Unit

ME(D)9.6/ME(D)9.6.1

CADILLAC, OPEL, SAAB

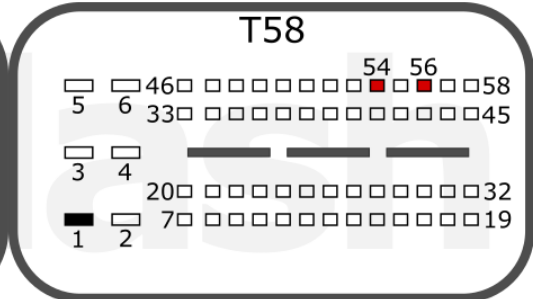
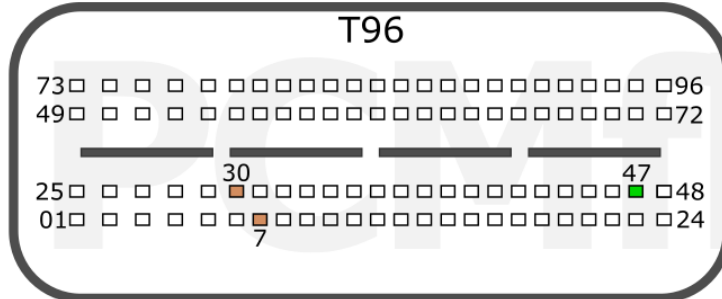

| | | | |
|-------------|-------------|---------------|------------|
| +12V | T58: 54, 56 | GPT | T96: 7, 30 |
| GND | T58: 1 | K-LINE | T96: 47 |

OPEL, CADILLAC

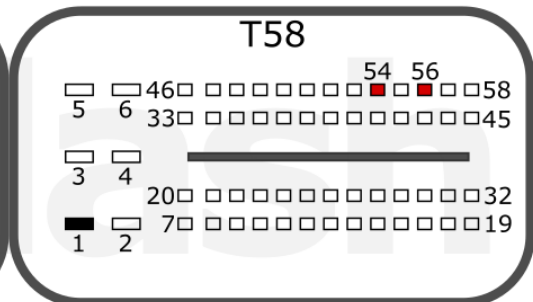

| | | | |
|-------------|-------------|---------------|------------|
| +12V | T58: 54, 56 | GPT | T96: 7, 35 |
| GND | T58: 1 | K-LINE | T96: 47 |

CADILLAC

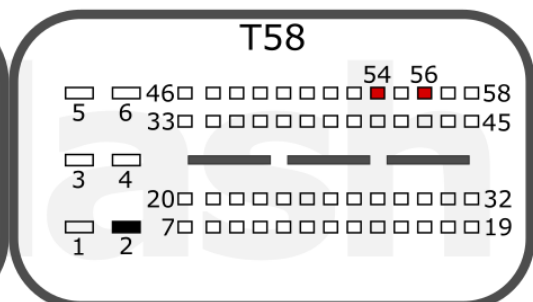
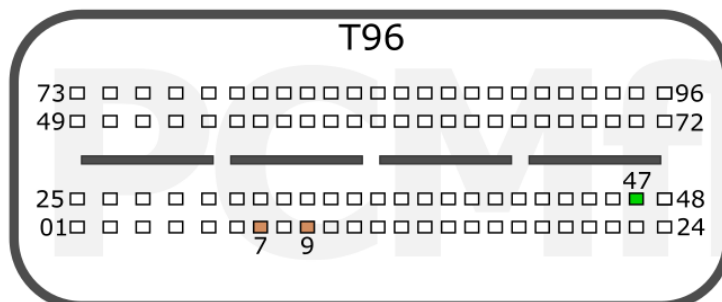

| | | | |
|-------------|-------------|---------------|-----------|
| +12V | T58: 54, 56 | GPT | T96: 7, 9 |
| GND | T58: 2 | K-LINE | T96: 47 |

CADILLAC

OPEL

SAAB

pcmflash.ru

v.1

2021-07-28

PCMflash

Engine Control Unit

ME9.0

Connection version 1

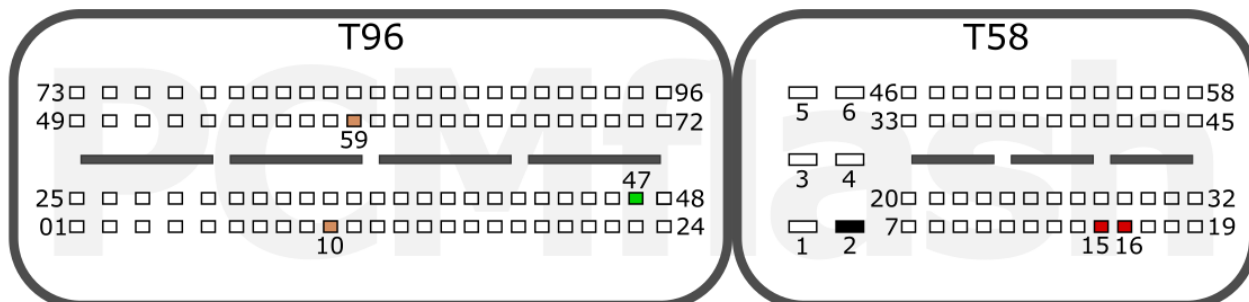

| | | | |
|-------------|-------------|---------------|-------------|
| +12V | T58: 15, 16 | GPT | T96: 59, 10 |
| GND | T58: 2 | K-LINE | T96: 47 |

Connection version 2

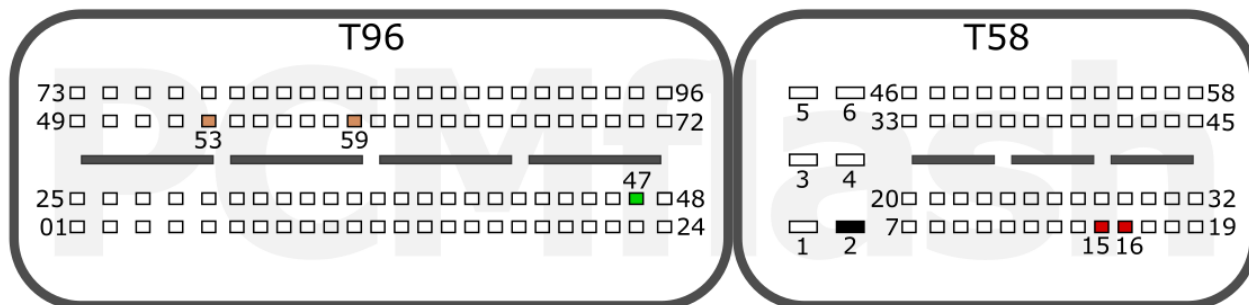

| | | | |
|-------------|-------------|---------------|-------------|
| +12V | T58: 15, 16 | GPT | T96: 59, 53 |
| GND | T58: 2 | K-LINE | T96: 47 |

Connection version 3

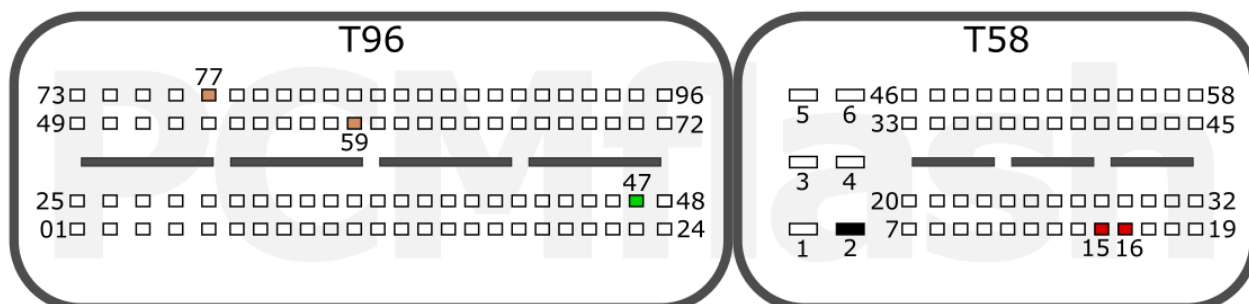

| | | | |
|-------------|-------------|---------------|-------------|
| +12V | T58: 15, 16 | GPT | T96: 59, 77 |
| GND | T58: 2 | K-LINE | T96: 47 |

VOLVO

pcmflash.ru

v.2

2021-11-03

PCMflash

Engine Control Unit

MED9.1/MED9.1.1

Connection version 1

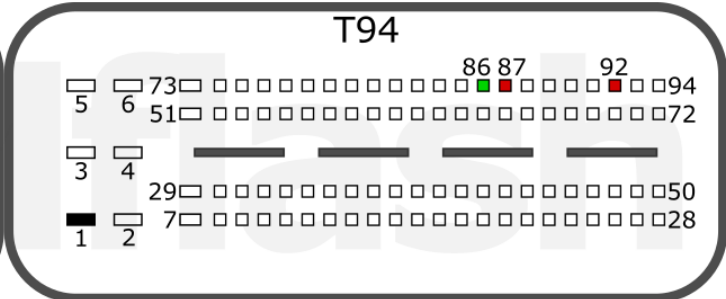
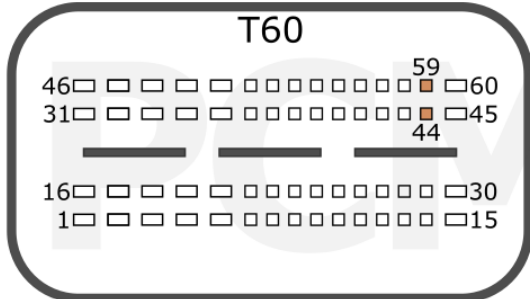

| | | | |
|-------------|-------------|---------------|-------------|
| +12V | T94: 87, 92 | GPT | T60: 59, 44 |
| GND | T94: 1 | K-LINE | T94: 86 |

Connection version 2

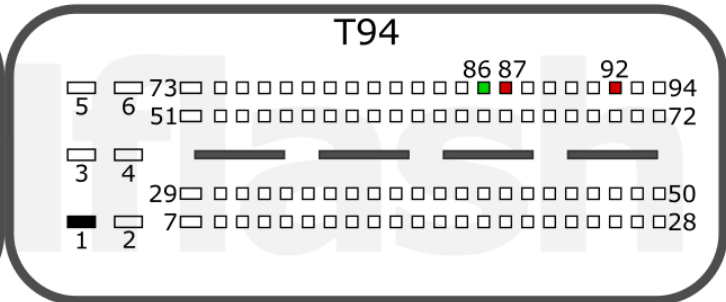
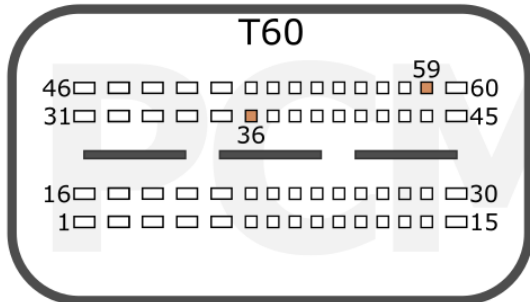

| | | | |
|-------------|-------------|---------------|-------------|
| +12V | T94: 87, 92 | GPT | T60: 59, 36 |
| GND | T94: 1 | K-LINE | T94: 86 |

Connection version 3

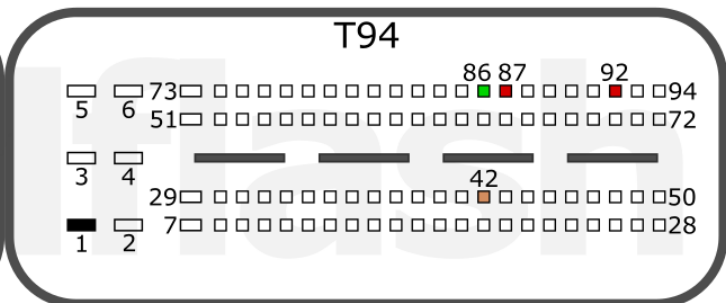
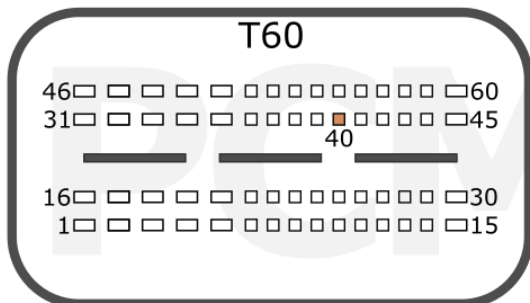

| | | | |
|-------------|-------------|---------------|-----------------|
| +12V | T94: 87, 92 | GPT | T60: 40, T94:42 |
| GND | T94: 1 | K-LINE | T94: 86 |

VAG

PCMflash

Electronic Control Unit

PSG16

Connection version 1

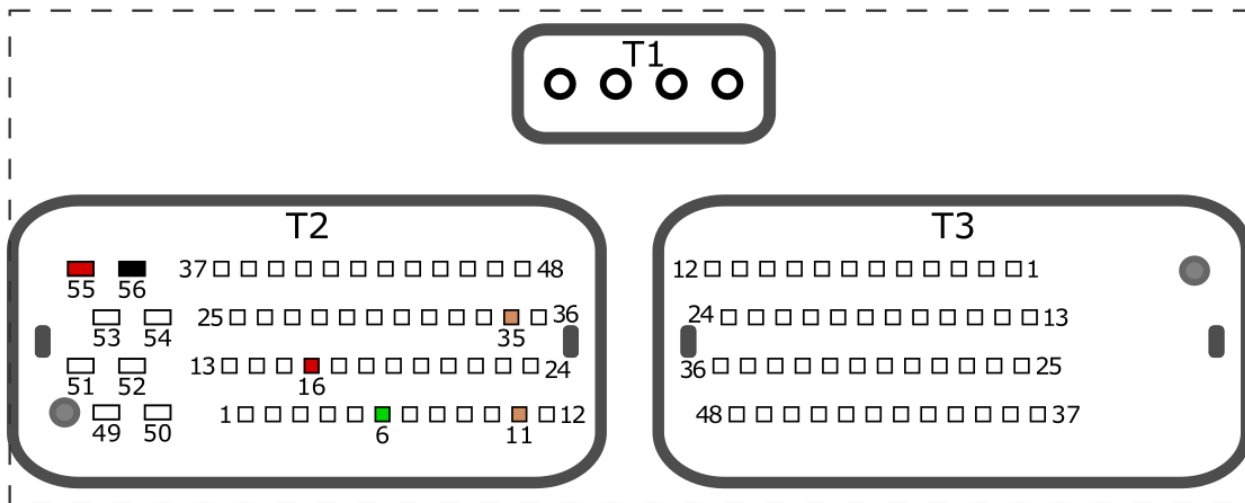

| | | | |
|-------------|------------|---------------|------------|
| +12V | T2: 55, 16 | GPT | T2: 11, 35 |
| GND | T2: 56 | K-LINE | T2: 6 |

Connection version 2

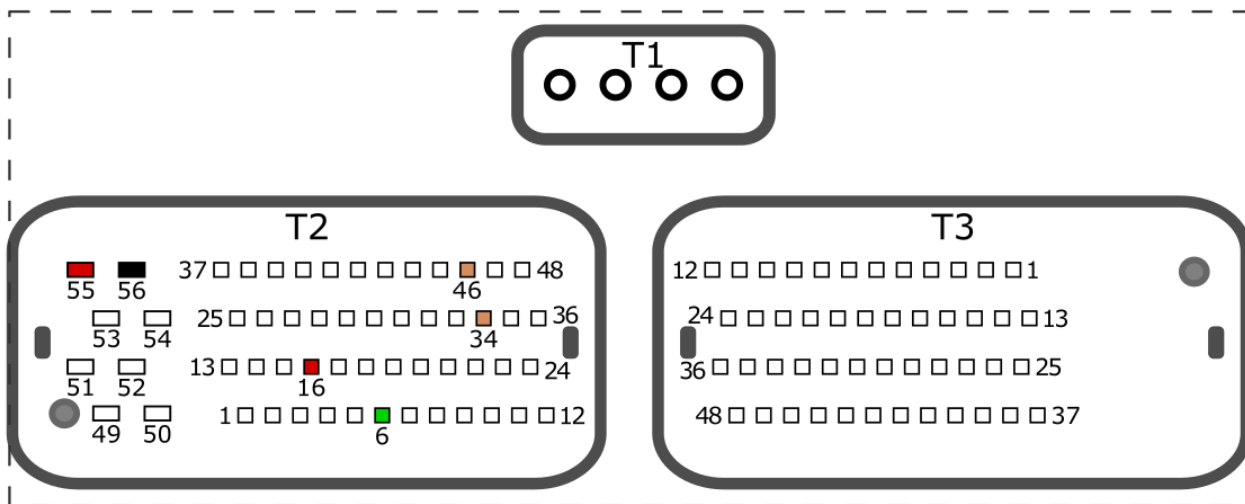

| | | | |
|-------------|------------|---------------|------------|
| +12V | T2: 55, 16 | GPT | T2: 46, 34 |
| GND | T2: 56 | K-LINE | T2: 6 |

OPEL

pcmflash.ru

v.1

2021-08-09

PCMflash

Transmission Control Unit

6HPxx Bosch TCU

Connection version 1

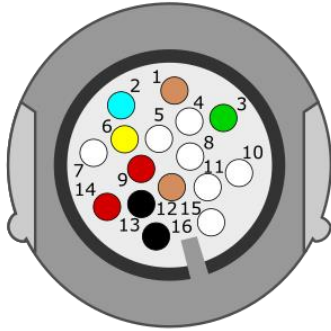

Type 1/Тип 1

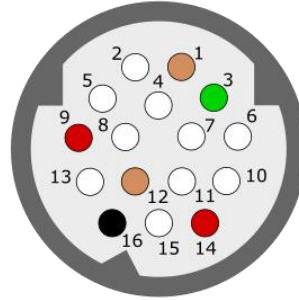

Type /Тип 2

| | | | |
|--------------|--------------|---------------|--------------|
| +12V | 9, 14 | GPT | 1, 12 |
| GND | 13, 16 | K-LINE | 3 |
| CAN-L | 2 (Not used) | CAN-H | 6 (Not used) |

Connection version 2

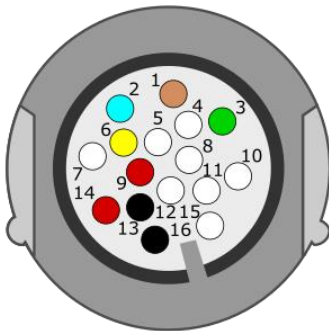

Type 1/Тип 1

GPT2
see below

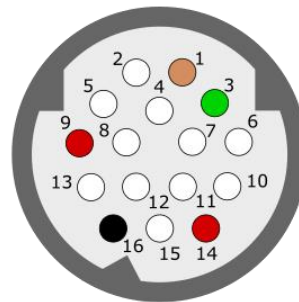

Type 2/Тип 2

Position switch/Позиционер

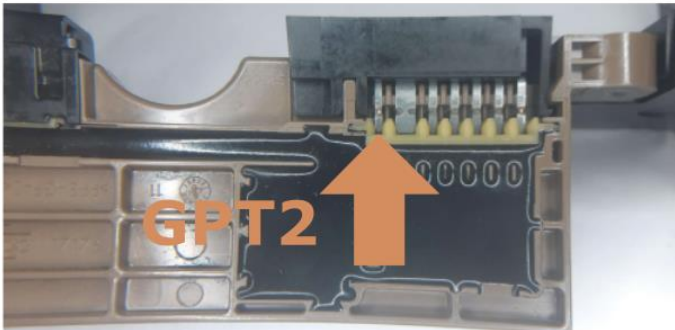

Remove cap/Снять крышку



BMW

JLR

VAG

pcmflash.ru

v.1

2021-11-24

PCMflash

Transmission Control Unit

RE5R05A TCU

Front side/Передняя сторона

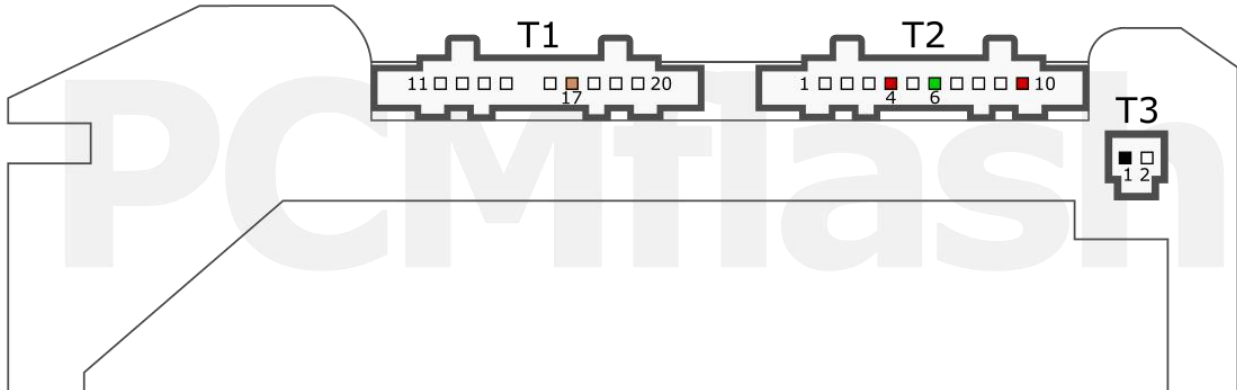

| | | | |
|-------------|----------|---------------|------------------|
| +12V | T2:4, 10 | GPT | T1:17, back side |
| GND | T3:1 | K-LINE | T2:6 |

Back side/Задняя сторона



See the next page/Смотри следующую страницу

NISSAN

pcmflash.ru

v.2

2021-12-06

PCMflash

Transmission Control Unit

RE5R05A TCU

With the lid open/С открытой крышкой

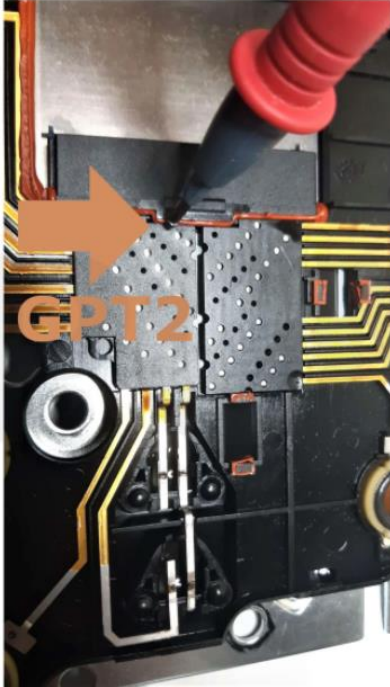

Option 1/Вариант 1

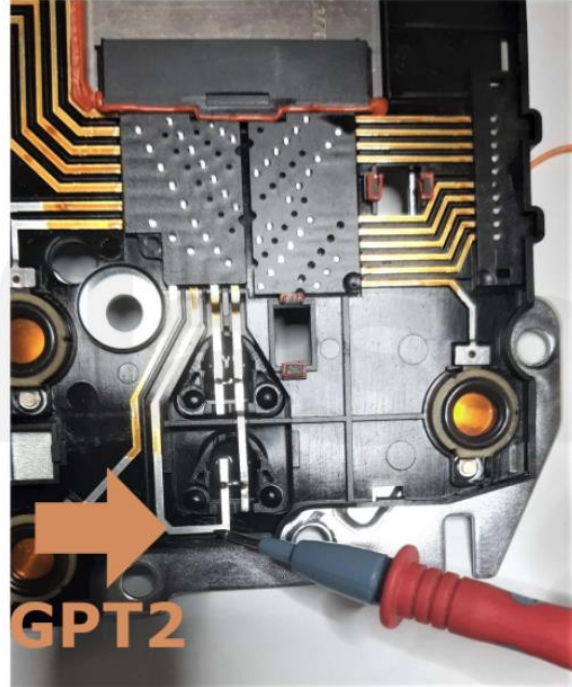

Option 2/Вариант 2

Without opening the lid/Без открытия крышки



Option 1/Вариант 1 (The best/ Лучший)

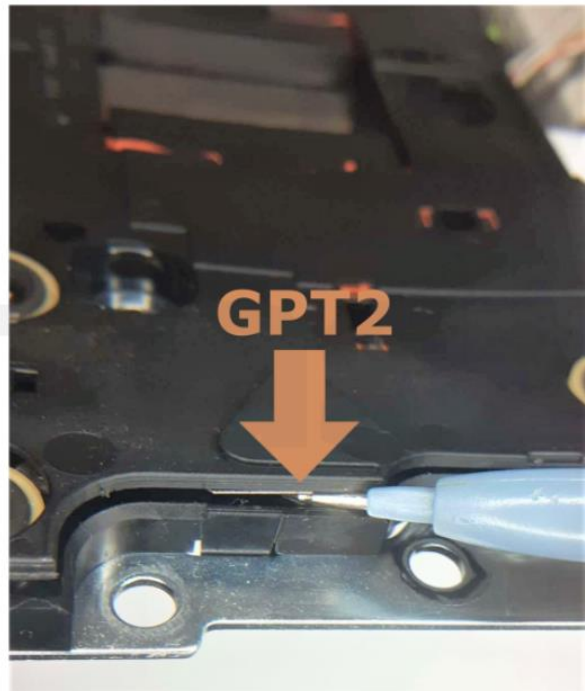

Option 2/Вариант 2

NISSAN

pcmflash.ru

v.2

2021-12-06

PCMflash

Transmission Control Unit

RE5R05A 0260550023 TCU

Front side/Передняя сторона

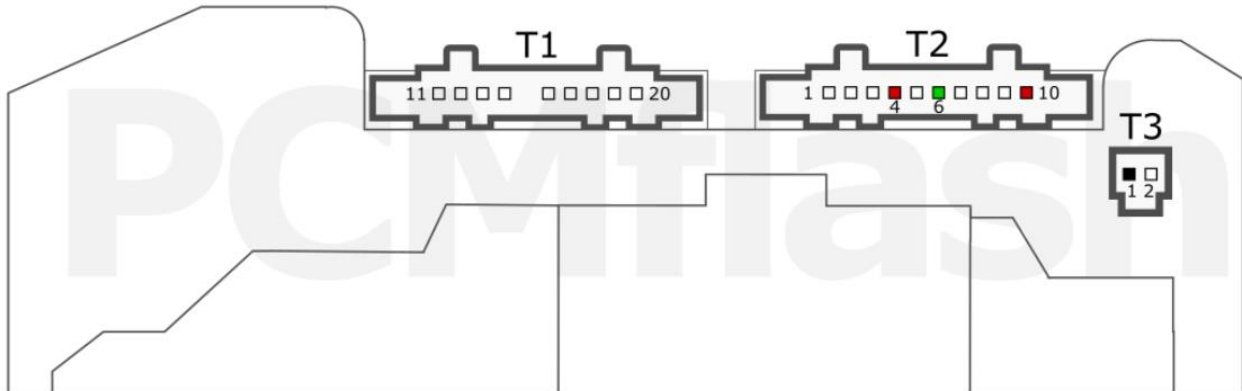

| | | | |
|-------------|----------|---------------|-----------|
| +12V | T2:4, 10 | GPT | Back side |
| GND | T3:1 | K-LINE | T2:6 |

Back side/Задняя сторона

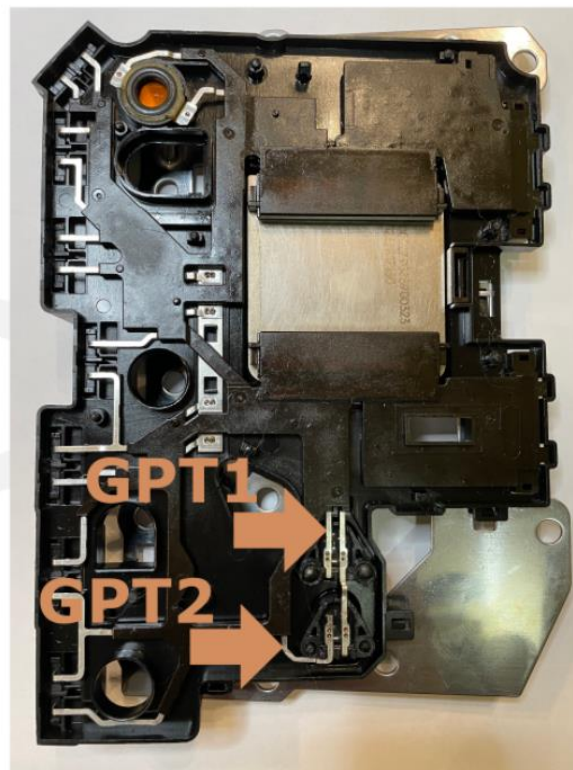

With the lid open/С открытой крышкой

NISSAN

pcmflash.ru

v.1

2021-12-08

PCMflash

Transmission Control Unit

TC14 TCU

KIA/HYUNDAI A5SR1/A5SR2/A6GF1

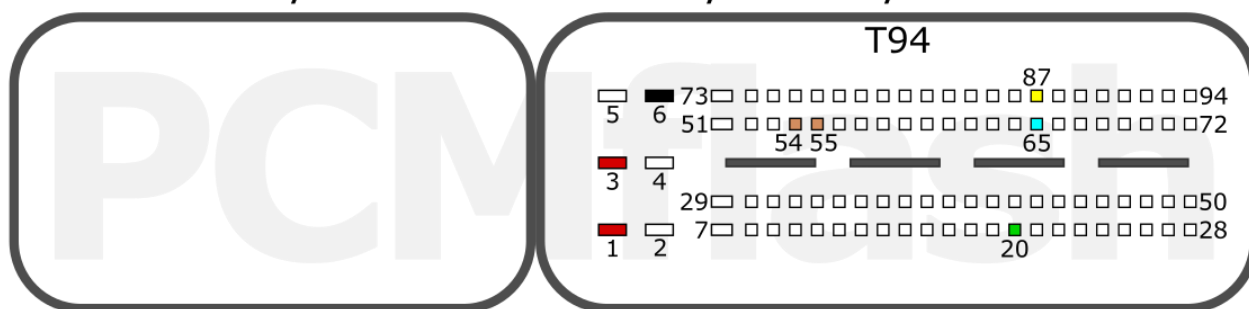

| | | | |
|--------------|--------------------|---------------|--------------------|
| +12V | T94: 1, 3 | GPT | T94: 54, 55 |
| GND | T94: 6 | K-LINE | T94: 20 |
| CAN-L | T94: 65 (Not used) | CAN-H | T94: 87 (Not used) |

KIA/HYUNDAI

pcmflash.ru

v.1

2021-11-22